

CAD FILE:

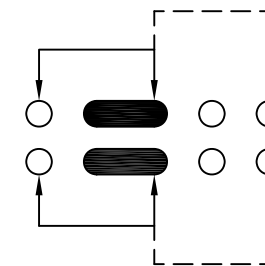

SCHEMATIC (NOT-SPECIFIED)

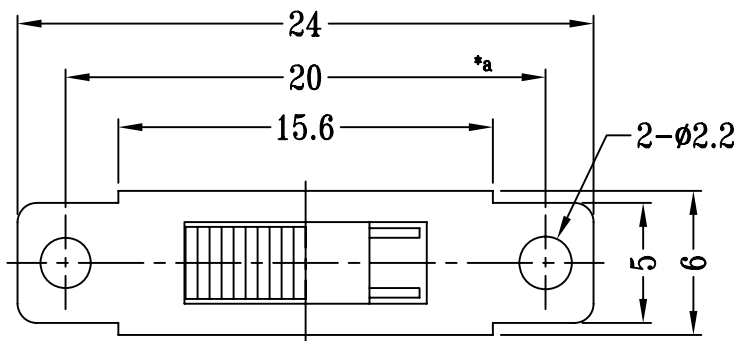
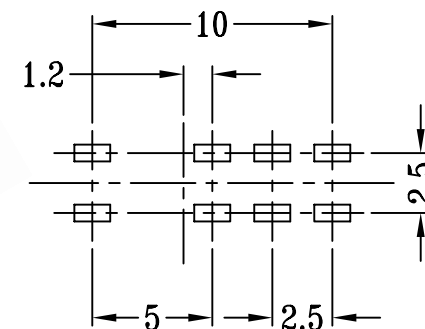
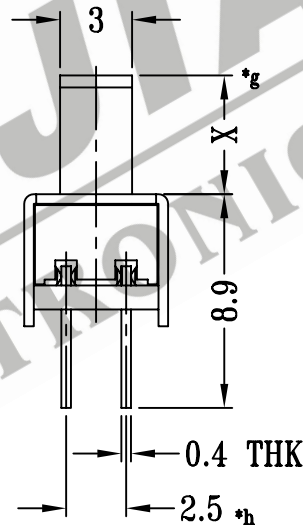
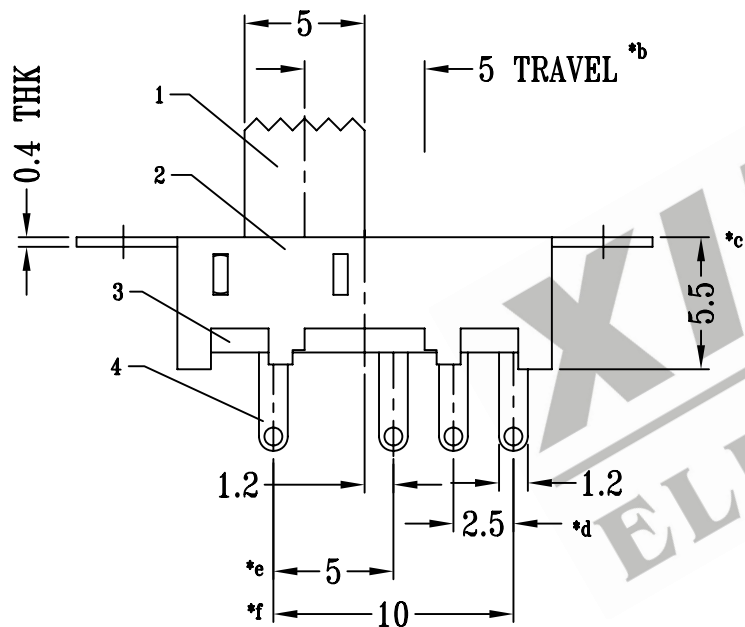

P.C.B LAYOUT

注:带*表示关键尺寸(8个)

NO.	PARTS	MATERIALS	Q'TY	FINISH	TOLERANCE UNLESS SPECIFIED	SHENZHEN XIEJIA ELECTRONICS CO.,LTD.					
8						ISSUE		DATE		DESCRIPTIONS OF REVISION	APPD.
7	STEEL BALL	STEEL	2	NATURAL	WITHIN: 1.5±0.1mm	TITLE : VERTICAL SLIDE SWITCH		UNIT : mm	DRWG NO.: XJ-DR-SS22J08-00		
6	SPRING	STEEL WIRE	1	TEMPER	OVER : 1.5±0.2mm	MODEL: SS-22J08		SCALE: 3:1	DWN.	ZHOUYU	2003-9-18
5	CONTACT CLIP	PBS	2	Ag CLAD		ALL MATERIALS MUST BE COMPLIANT TO ROHS			CHK'D	FANGYING	2003-9-18
4	TERMINAL	BRASS STRIP	8	Ag PLATED OVER Ni PLATED					APPD.	KANGXINAN	2003-9-18
3	BASE	PHENOLIC RESIN	1	NATURAL							
2	FRAME	STEEL STRIP	1	Ni PLATED							
1	KNOB	POM	1	BLACK							